

Data Sheet

GreaseShot™

Product Description

GreaseShot is an automatic biological drain dosing system designed to keep commercial foodservice drains clear of fats, oils, grease (FOG), and starches.

Key Features & Benefits

- Environmentally Friendly, minimal monthly disposable packaging
- Reusable container
- Efficient timer mechanism: An "all in one" bio release timer.
- Powered by just 2x AA batteries for low cost ongoing operational running

Highly Efficient Dosing

All-day protection this ensures the system remains effective, even when drains are exposed to cleaning chemicals, hot water, and other disruptive agents.

Unmatched Reliability

With minimal moving parts, GreaseShot is built for durability and long-term cost efficiency. Its simplified design significantly reduces the risk of mechanical failure.

Superior Bio-Remediation

GreaseShot features a powerful, high-bacteria-count formulation (*over a billion per dose*) specifically engineered to break down fats, oils, grease, and starch. It remains effective across varying pH levels and prevents the reformation or solidification of waste downstream.

Quick and Easy Installation

Installation is straightforward:
Mount the system at 1200mm above finished floor level (AFFL)

Secure with four screws

- Insert the drip feed into the drain
- Fill the container—done!

GreaseShot is easy to install, just four screws , insert the "drip feed" into the drain, fill the bottle & you're all set. Install GreaseShot 1200mm AFFL, above the height of the work table.

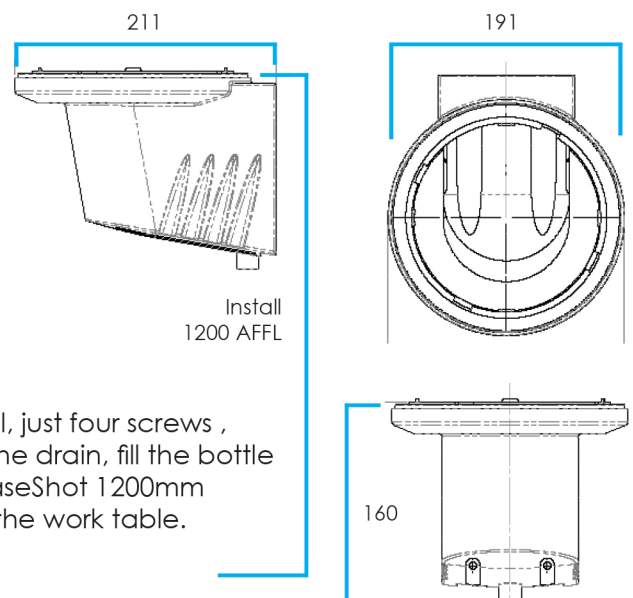
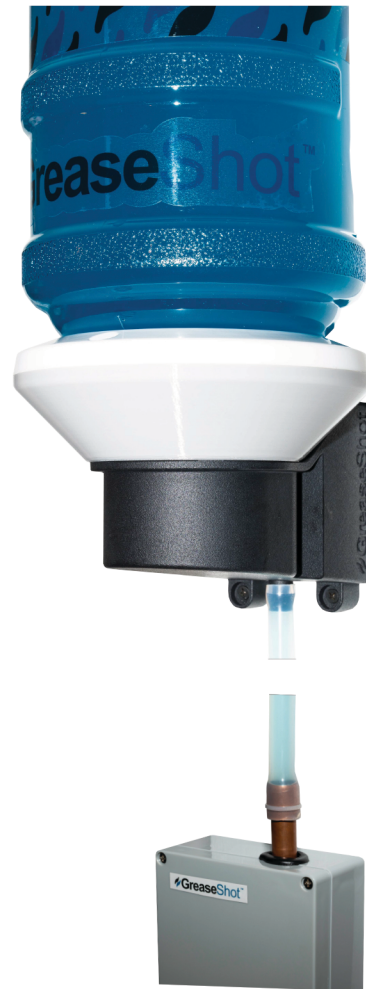

**Kitchen
Flow
Solutions**

T: 0121 293 0800
sales@kitchenflowsolutions.co.uk
www.kitchenflowsolutions.co.uk